

Lean Material Flow Solutions

ProFlow™ Series

# Delivery Carts

1350 Rockefeller Rd., Wickliffe, OH 44092, PH 440.943.4111, info@KtecInc.com, www.KtecInc.com

## DELIVERY CARTS

K-Tec three shelf delivery carts bring flexibility and top quality to complement **lean material flow** programs. Features include:

- 2 Adjustable Shelves with Removable Halves
- HD Auto-Release Floor Lock
- Auto-Hitch and Self Stowing Towbar
- Low Push/Pull Force 6-Wheel System
- Easy Towing of Long Trains Around Tight Aisles
- Less Than 36" Cart Width for Narrow Aisles

## INDUSTRY LEADING DESIGN

Carts meet standard ergonomic limits for manual push / pull forces with heavy payloads and standup to tough loading conditions. FEA (finite element analysis) puts stiffness and weight where needed

to produce carts as light and rugged as possible. Innovations such as MPP™ (modified pivot point) caster steering allow significant improvements in tracking and turning while maintaining low frame height and manual pushing capability. Numerous "attention to detail" features help K-Tec meet rigorous **safety**, reliability and durability standards. K-Tec ProFlow™ Series carts carry a **two (2) year warranty**.<sup>1</sup>

## COMMITMENT TO SUCCESS

K-Tec identifies and benchmarks relevant applications, addresses ergo/safety issues and provides on-site feasibility reviews where required. Application engineers are available by conference call or direct appointment to help walk through the early planning and front end design phase of lean material flow projects.<sup>2</sup>

K-Tec also designs ergo-support products such as lifts and conveyors to provide an integrated, dependable solution. A "try before you buy" **demo program** for qualified customers delivers a hands on look at our products without wasting investment dollars.

1. See web site for warranty detail. 2. May be subject to consulting charges.

**Distributed By:**



Model Shown: KT2-34D3



Model Shown: KT2-34D3  
w/lift-out shelf removed

# Lean Material Flow Solutions

## Delivery Carts

1350 Rockefeller Rd., Wickliffe, OH 44092, PH 440.943.4111, info@Kteclnc.com, www.Kteclnc.com

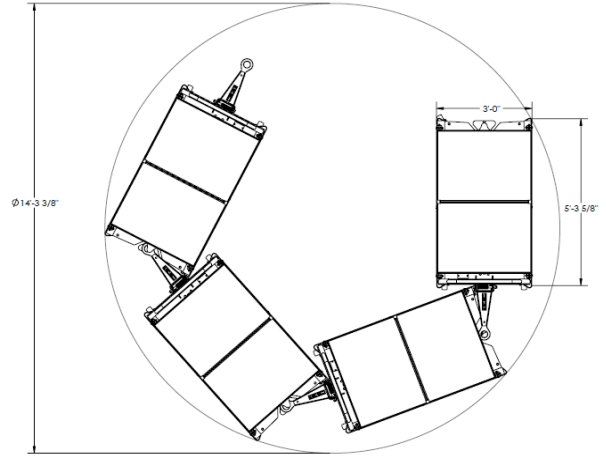
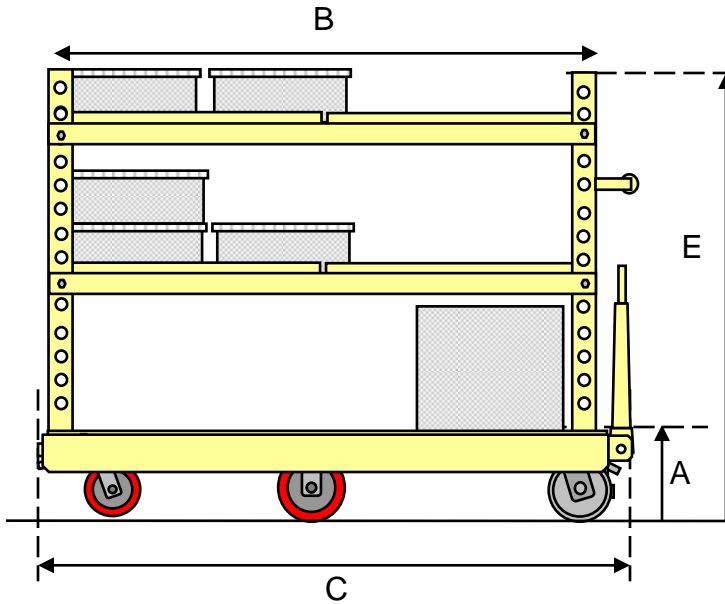

### Delivery Carts

Model: KT2-34D3

Dimensions	
Floor to Lower Deck Height, A	10.5"
Usable Shelf Area, B	54"L x 34"W
Overall Cart Length, C	63"
Overall Cart Width, D	35.6"
Cart Height, E	~50"
Maximum Load Top Shelf (to resist tipping at 5mph)	650 lbs.
Standard Features	
2 Adjustable Shelves w/Removable Halves	✓
4-Wheel Caster Steer w/Kingpinless Swivels, Hybrid Low Push/Pull Force	
6-Wheel Caster Steer w/Kingpinless Swivels, Hybrid Low Push/Pull Force (FOR RAMP USE CONSULT FACTORY)	✓
Welded Steel, Industrial-Duty Perimeter Frame w/Powder Paint Finish	✓
Precision Sealed Wheel and Swivel (rotational deck if applicable) Bearings	✓
"No-Bend" Heavy-Duty Auto-Hitch and Self Stowing, Reinforced Towbar	✓
Heavy Duty Floor Lock w/Auto-Release (towbar activated)	✓
MPP™ (modified pivot point) Caster Steering (FOR RAMP USE CONSULT FACTORY)	✓
Cart Tare Weight	570 lbs.
Total Load Capacity (all shelves, see Top Shelf Max. Load above)	2000 lbs.
Rated Load Capacity (to meet ergo guidelines w/standard wheels)	1500 lbs.

Application photos, technical specifications and CAD drawings can be found on the web site at [www.Kteclnc.com](http://www.Kteclnc.com)