

ROLLER DECK CARTS

K-Tec roller deck carts deliver flexibility and top quality to complement **lean material flow** programs.

- Auto-Release Floor Lock
- Choice of Two (2) Popular Deck Sizes
- Low Push/Pull Force 4 or 6 Wheel Systems
- Built-In Pocket For Pneumatic or Hydraulic Lifts
- Auto-hitch and self stowing towbar

INDUSTRY LEADING DESIGN

Carts meet standard ergonomic limits for manual push/pull forces with heavy payloads and standup to tough loading conditions. FEA (finite element analysis) puts stiffness and weight where needed to produce carts as light and rugged as

possible. Innovations such as MPP™ (modified pivot point) caster steering allow significant improvements in tracking and turning resulting in low frame height and manual pushing capability. Numerous “attention to detail” features help K-Tec meet rigorous **safety**, reliability and durability standards. K-Tec ProFlow™ Series carts carry a **two (2) year warranty**.¹

COMMITMENT TO SUCCESS

K-Tec identifies and benchmarks relevant applications, addresses ergo/safety issues and provides on-site feasibility reviews where required. Application engineers are available by conference call or direct appointment to help walk through the early planning and front end design phase of lean material flow projects.²

K-Tec also designs ergo-support products such as lifts and conveyors to provide an integrated, dependable solution. A “try before you buy” **demo program** for qualified customers delivers a hands on look at our products without wasting investment dollars.

1. See web site for warranty detail. 2. May be subject to consulting charges.

Distributed By:



Model Shown: KT2-49NRC.13”



Model Shown: KT2-49NRC.15”

Lean Material Flow Solutions

Roller Deck Carts

1350 Rockefeller Rd., Wickliffe, OH 44092, PH 440.943.4111, info@KtecInc.com, www.KtecInc.com

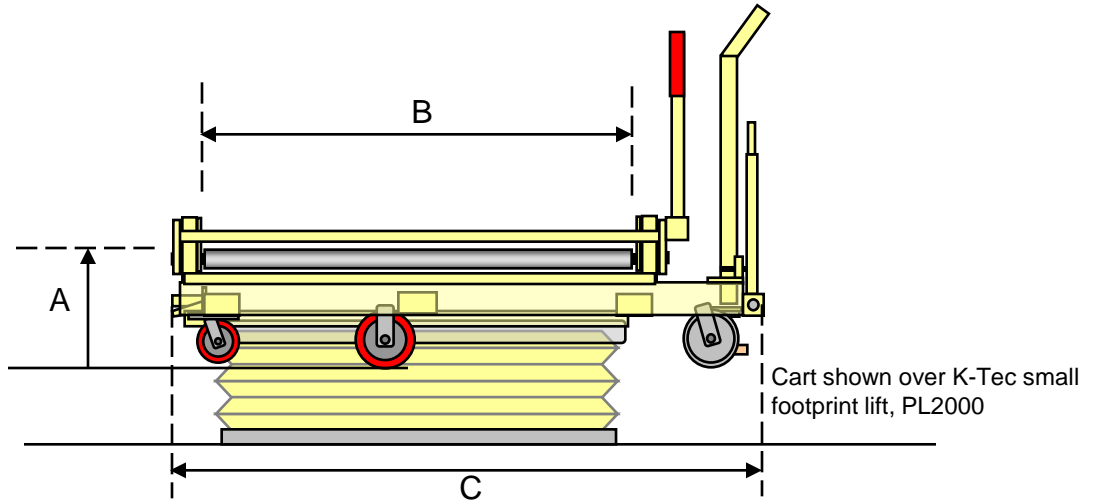

Roller Deck Carts

Model: KT2-37NRC.xx"

Model: KT2-49NRC.xx"

Dimensions	Model: KT2-37NRC.xx"	Model: KT2-49NRC.xx"
Floor to Deck Height, A ¹	13" - 24"	13" - 24"
Usable Deck Size, B	37.5" x 37.5"	49.5" x 49.5"
Overall Cart Length, C	57"	69"
Overall Cart Width, D	41"	53"
Roller Diameters, Lead-In / Deck	2.5" / 1.9"	2.5" / 1.9"
Roller Spacing, Tight	1.9" on 2.3" ctrs.	1.9" on 2.5" ctrs.
Standard Features		
4-Wheel Caster Steer w/Kingpinless Swivels, Hybrid Low Push/Pull Force	✓	
6-Wheel Caster Steer w/Kingpinless Swivels, Hybrid Low Push/Pull Force (FOR RAMP USE CONSULT FACTORY)		✓
Welded Steel, Industrial-Duty Perimeter Frame w/Powder Paint Finish	✓	✓
Ajustable Roller Deck Height (specify shipped height by replacing XX" in model number with height when ordering)	✓	✓
Non-rotational Roller Deck with Manual Dunnage Lock Bar on Both Sides of Frame	✓	✓
Built-in Lift Pocket Fits 7" x 24" x 38" Pneumatic or Hydraulic Lifts	✓	✓
Precision Sealed Wheel and Swivel Bearings	✓	✓
"No-Bend" Heavy-Duty Auto-Hitch and Self Stowing, Reinforced Towbar	✓	✓
Heavy Duty Floor Lock w/Auto-Release (towbar activated)	✓	✓
MPP™ (modified pivot point) Caster Steering (FOR RAMP USE CONSULT FACTORY)		✓
Cart Tare Weight	470 lbs.	570 lbs.
Deck Load Capacity	2000 lbs.	2000 lbs.
Rated Load Capacity (to meet ergo guidelines w/standard wheels)	1500 lbs.	1500 lbs.

NOTES: 1. Cart roller heights available from 13" to 24" (floor to top of roller), please specify

Application photos, technical specifications and CAD drawings can be found on the web site at www.KtecInc.com